

TLF Series NEMA Single-Phase Motors Aluminum TEFC

• 1/4HP thru 10HP

STANDARD FEATURES

- 40°C Ambient Rating
- Aluminum Housing
- Ball bearings
- IP 55 Rated
- Removable Feet
- Corrosion Resistant Hardware
- Double Lip Oil Seals

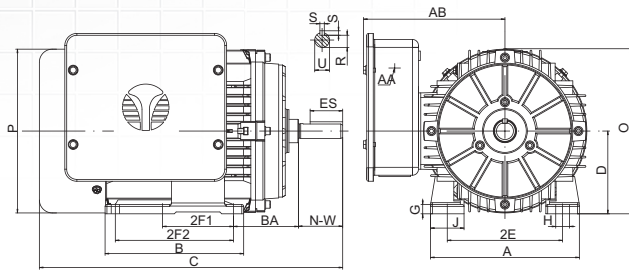
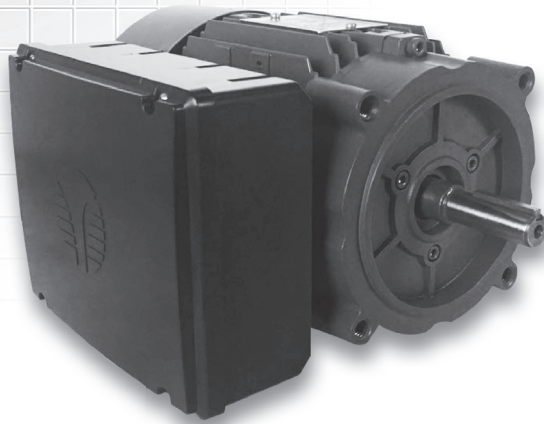

Figure 1 56 thru 210T (Foot Mounting)

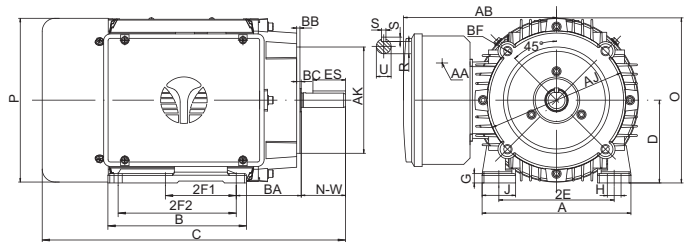

Figure 2 56 thru 140T (C- Face)

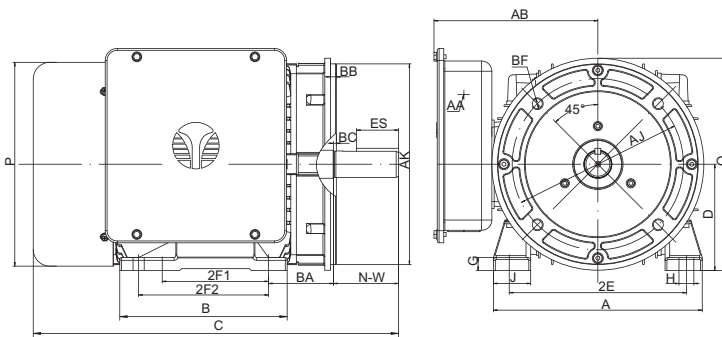

Figure 3 180T, 210T (C- Face)

Overall & Installation Dimensions

Frame	Foot Mounting							Shaft					General					Bearings		C-Face						
	A	B	D	2E	2F1	2F2	BA	H	U	N-W	R	ES	S	AA	G	J	AB	O	P	DE	NDE	AJ	AK	BB	BC	BF
56	6.3	3.95	3.5	4.88	3		2.75	0.73×0.335	0.625	1.875	0.517	1.375	0.1875	1/2-14NPT3/4-14NPT	0.43	1.37	6.05	6.6	6.2	6204	6204	5.875	4.5	0.16	-0.19	4×3/8-16UNC
56H	6.3	5.9	3.5	4.88	3	5	2.75	0.58×0.335	0.625	1.875	0.517	1.375	0.1875	1/2-14NPT3/4-14NPT	0.39	1.41	6.5	7.0	6.95	6205	6205	5.875	4.5	0.16	-0.19	4×3/8-16UNC
140T	6.9	5.86	3.5	5.5	4	5	2.25	0.50×0.35	0.875	2.25	0.771	1.375	0.1875	1/2-14NPT3/4-14NPT	0.47	1.41	6.5	7.0	6.95	6205	6205	5.875	4.5	0.16	0.12	4×3/8-16UNC
180T	8.85	7.1	4.5	7.5	4.5	5.5	2.75	0.59×0.433	1.125	2.75	0.986	1.75	0.25	φ1.11, φ1.33	0.55	1.57	6.95	8.85	8.65	6306	6206	7.25	8.5	0.25	0.12	4×1/2-13UNC
210T	10.3	8.85	5.25	8.5	5.5	7	3.5	0.59×0.433	1.375	3.375	1.201	2.41	0.312	φ1.11, φ1.33	0.63	1.73	8.13	10.4	10.3	6308	6208	7.25	8.5	0.25	0.25	4×1/2-13UNC



NEMA TEFC Single-Phase Motors Technical Data

HP	Full Load Speed, RPM	Frame Size	EFF. 100% FL	Power Factor 100% FL	IFL 230V A	Full Load Torque Lb-Ft	Moment Of Inertia Lb-Ft Squared	Locked Rotor		TST TFL	TM TFL	Service Factor	Dim "C"
								KVA Code	II/In				
1/4	3530	56	68.0	92	1.25	0.36	0.0121	N	9.60	3	2.6	1.15	11.3
	1735	56	70.0	86	1.30	0.73	0.0208	M	8.50	3.1	2.7	1.15	11.3
1/3	3530	56	72.0	92	1.64	0.5	0.0134	M	9.50	3	2.6	1.15	11.3
	1735	56	74.0	86	1.71	1.01	0.0268	L	7.90	3.1	2.7	1.15	11.3
1/2	3530	56	74.0	93	2.34	0.74	0.0161	M	9.40	3	2.6	1.15	11.3
	1730	56	77.0	88	2.37	1.51	0.0327	K	8.10	3.1	2.7	1.15	11.3
3/4	3530	56	77.0	93	3.37	1.10	0.0202	L	8.90	3	2.6	1.15	11.3
	1730	56	78.5	88	3.34	2.24	0.0387	K	8.10	3	2.5	1.15	11.3
1	3530	56H	78.5	95	4.37	1.50	0.0320	L	8.9	3.3	2.6	1.15	13.1
		140T											13.2
	1740	56H	80.0	90	4.53	3.04	0.0619	K	7.8	3	2.4	1.15	13.1
		140T											13.2
1.5	3530	56H	81.5	95	6.18	2.20	0.0377	K	8.5	3.3	2.6	1.15	13.1
		140T											13.2
	1740	56H	81.5	92	6.38	4.45	0.0750	H	6.9	2.8	2.3	1.15	13.1
		140T											13.2
2	3530	56H	82.5	95	8.32	2.99	0.0413	K	8.4	3.1	2.5	1.15	13.1
		140T											13.2
	1735	56H	82.5	92	8.59	6.09	0.0880	H	6.4	2.6	2.2	1.15	13.1
		140T											13.2
3	3530	56H	84.0	96	11.9	4.39	0.0484	J	8.4	3.1	2.5	1.15	13.1
		140T											13.2
	3530	180T	84.0	96	11.9	4.39	0.1139	H	7.5	3.5	2.2	1.15	15.6
5	3530	180T	84.0	96	20.0	7.38	0.1360	H	7.0	3.5	2.2	1.15	15.6
	1740	180T	84.0	94	20.4	14.98	0.3037	G	6.4	3.2	2.2	1.15	15.6
7.5	3530	210T	84.5	98	28.9	10.98	0.3417	H	7.6	3.5	2.2	1.15	18.6
	1750	210T	84.5	96	29.5	22.14	0.9255	H	7.0	3	2.4	1.15	18.6
10	3530	210T	86.0	98	38.7	14.97	0.4438	H	8.0	3.5	2.2	1.15	18.6
	1750	210T	85.5	96	39.7	30.19	1.1106	H	7.6	2.8	2.2	1.15	18.6

IEC MOTOR

FIRE PUMP MOTOR

GOST MOTOR

VHS MOTOR

H.T. MOTOR

S.S. MOTOR

NEMA MOTOR

EC MOTOR